

# Merlin Pro



**GS UK Limited** are one of Europe's leading companies in industrial embroidery products and have been supplying the textile industry for over 25 years.

GS's sister company **CadCam Technology Ltd** manufacture the FB series laser cutters and laser engraving systems which they sell worldwide through their distributor network. In addition they also develop software systems for a range of applications.

Over the past 25 years, GS UK has responded to the seismic changes that have affected the UK's commercial embroidery industry, adding new products and developing existing technology to continue to meet the modern day embroiderer's changing needs.

For example, GS UK along with CadCam Technology are credited with developing one of the first embroidery digitising systems in the mid eighties. This groundbreaking technology has evolved into ApS-Ethos, one of the most comprehensive suites of embroidery software in the industry.

CCT's research and development in Laser technology has had a large impact on the success of the two companies. Laser machinery allows manufacturers to cut and etch a massive variety of materials quickly and accurately. This technology has been particularly effective in the embroidery market, being used to cut appliqués and badges.

It is the combination of GS UK's embroidery knowledge and CadCam's manufacturing experience that has led to the production of the GS Merlin range of industrial embroidery machines.

### Support

Having been the sole UK distributor of a leading brand of embroidery machines for over 15 years, GS UK already have the necessary infrastructure in place to offer a first class support system. Our team of experienced embroidery machine engineers can service the whole of the UK and Ireland.

### Training & Warranty

All of our machines include installation, delivery and comprehensive training by our own engineers. A two year warranty is standard on all machines, subject to an annual service by a Merlin Pro engineer. See terms and conditions for more information.

# Merlin Pro

## GS - 1501

### 15 Needle Single Head Machine



#### Main Features

- 1 Head - 15 Needles
- Max Speed - 1200 SPM
- Maximum Sewing Area: 550 mm x 350 mm (22" x 14")
- Touch Screen - 260 mm (10.4")
- On board Monogram Maestro Software
- 1,000,000 Stitch Memory
- USB Port Ready
- 270° Wide Angle Cap System
- Networkable and Wi-Fi Capable
- Bobbin Winder
- Automatic Thread Trimmer & Auto Colour Change
- Thread Break Detection

#### Frames & Hoops Included

- 2 x Circular Hoops – 9 cm (3.5")
- 2 x Circular Hoops – 12 cm (4.7")
- 2 x Circular Hoops – 15 cm (5.9")
- 2 x Circular Hoops – 20 cm (9")
- 2 x Large Back Hoops – 29 cm x 29 cm (12" x 12")
- 1 x Sash Frame / Border Frame – 54 cm x 36 cm (21" x 14")

#### Cap Frame Attachment Included

- 1 x 270° Wide Cap Frame Driver
- 2 x Cap Frames
- 1 x Snap in & Snap Out Cap Frame Device

#### Machine Specification

Model: GS Merlin 1501

Needles: 15

Head(s): 1

Maximum speed: 1200 SPM

Net Weight: 90 kgs / 200 lbs

Machine Dimensions:

75 cm x 70 cm x 85 cm (29.5" x 27.5" x 33.5")

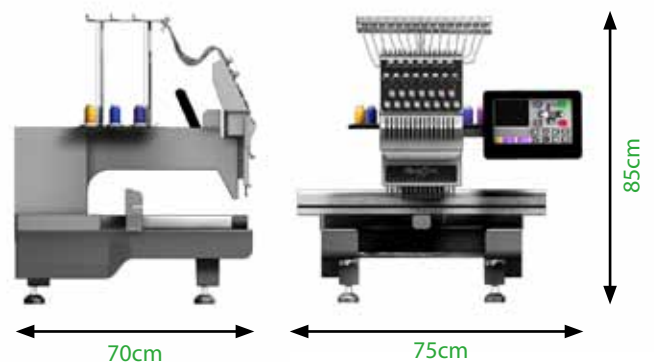

#### Accessories/Options

Camera, Sequin Device, Belt Attachment, LED Trace

# Merlin Pro

## GS - 1204

### 12 Needle Four Head Machine

#### Main Features

- 4 Heads - 12 Needles
- Max Speed - 1000 SPM
- Maximum Sewing Area: 400 mm x 450 mm (15.5" x 17.5")
- Touch Screen - 260 mm (10.4")
- On board Monogram Maestro Software
- 1,000,000 Stitch Memory
- USB Port Ready
- 270° Wide Angle Cap System
- Networkable and Wi-Fi Capable
- Bobbin Winder
- Automatic Thread Trimmer & Auto Color Change
- Thread Break Detection



#### Frames & Hoops Included

- 8 x Circular Hoops – 9 cm (3.5")
- 8 x Circular Hoops – 12 cm (4.7")
- 8 x Circular Hoops – 15 cm (5.9")
- 8 x Circular Hoops – 19 cm (7.5")
- 8 x Large Back Hoops – 30 cm x 30 cm (11.8" x 11.8")
- 1 x Sash Frame / Border Frame

#### Cap Frame Attachment Included

- 4 x 270° Wide Cap Frame Driver
- 8 x Cap Frames
- 1 x Snap in & Snap Out Cap Frame Device

#### Machine Specification

Model: GS Merlin 1204

Needles: 12

Head(s): 4

Maximum Speed: 1000 SPM

Net Weight: 600KG / 1322 lb

Machine Dimensions:

At Delivery: 250 cm x 92 cm x 178 cm (98.4" x 36.2" x 70")

After Set Up: 250 cm x 130 cm x 178 cm (98.4" x 51.1" x 70")

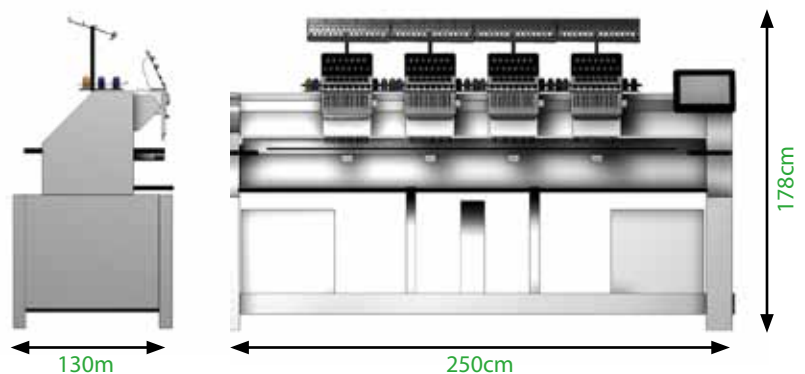

#### Accessories/Options

Camera, Sequin Device, Belt Attachment, LED Trace

# Merlin Pro

## GS - 1206

### 12 Needle Six Head Machine

#### Main Features

- 6 Heads - 12 Needles
- Max Speed - 1000 SPM
- Maximum Sewing Area: 400mm x 450mm (15.5" x 17.5")
- Touch Screen - 260 mm (10.4")
- On board Monogram Maestro Software
- 1,000,000 Stitch Memory
- USB Port Ready
- 270° Wide Angle Cap System
- Networkable and Wi-Fi Capable
- Bobbin Winder
- Automatic Thread Trimmer & Auto Color Change
- Thread Break Detection



#### Frames & Hoops Included

- 12 x Circular Hoops – 9 cm (3.5")
- 12 x Circular Hoops – 12 cm (4.7")
- 12 x Circular Hoops – 15 cm (5.9")
- 12 x Circular Hoops – 20 cm (7.9")
- 12 x Large Back Hoops – 30 cm x 30 cm (11.8" x 11.8")
- 1 x Sash Frame / Border Frame

#### Cap Frame Attachment Included

- 6 x 270° Wide Cap Frame Driver
- 12 x Cap Frames
- 1 x Snap in & Snap Out Cap Frame Device

#### Machine Specification

Model: GS Merlin 1206

Needles: 12

Head(s): 6

Maximum Speed: 1000 SPM

Net Weight: 750KG / 1653 lb

Machine Dimensions:



130cm

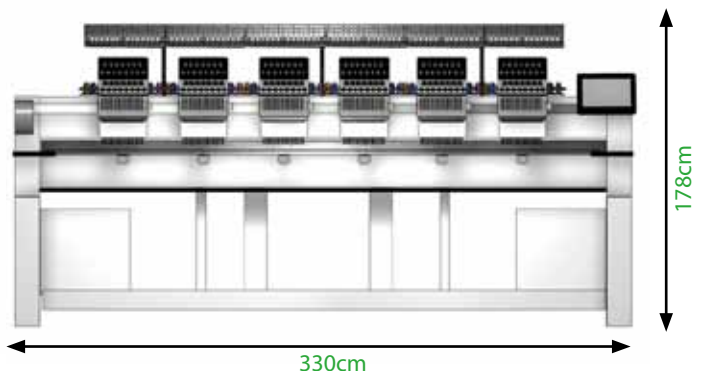

330cm

178cm

At Delivery: 330 cm x 92 cm x 178 cm (129.9" x 36.2" x 70")

After Set Up: 330 cm x 130 cm x 178 cm (129.9" x 51.1" x 70")

#### Accessories/Options

Camera, Sequin Device, Belt Attachment, LED Trace

# Merlin Pro

## Machine Features

Included with every embroidery machine in the Merlin Pro range is a touch screen console. This allows access to the control software on the machine, enabling the user to select a frame size, input colours, control stitching speeds etc. In addition to this control software, every machine also has our Monogram Maestro software loaded. This is a powerful package that re-introduces the concept of 'monogramming' directly on the embroidery machine rather than having to use a separate software package on a PC.

### Touch Screen Console

- Frame Selection
- Input Colours
- Control Sewing Speeds
- Trace
- Set Origin

### Design Creation

- 56 Fonts
- 30 Monogram Designs
- 230 Stock Designs
- Lettering Deform Tools

### Design Editing

- Re-Order Designs
- Rotate
- Mirror
- Rescale

## Editing Designs



Load in one of your own logos or choose one from the library of 120+ designs and add the text you require. The height, colour and position of the text can be adjusted, it is even possible to changing the stitching order of a design. Designs may also be rotated, mirrored and re-scaled.

## Frame Selection



The touch screen control panel displays the frames available. Once a frame is selected, simply load in your design and if the chosen frame is not large enough for the design you will be prompted to select another.

In addition to the frame display an LED trace function is available.

## Monogramming



The Monogram Maestro software includes 56 fonts, which can be created in any height/colour etc. A selection of lettering deforms are available.

Numerous monogram designs are also included, simply select the monogram style you want to use and type out the initials you need.

# Merlin Pro

## Options

### Framing Jig



The GS three in one adjustable framing jig allows framing for both adult and child sized garments. The multi-position design is both compact and versatile enabling you to use it in the smallest of spaces. The built in sleeve jig has a clip for holding Backing and adjustable pins for accurate garment positioning every time.

### Fast Frames

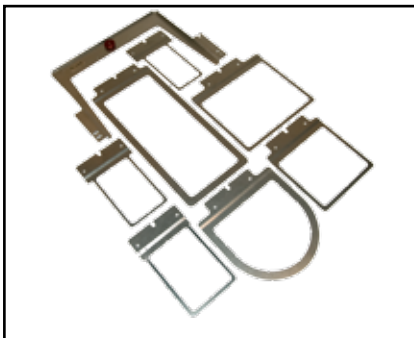

Sew Where You Have Never Sewn Before Fast Frames are a non-hoop embroidery frame system. This 7 in 1 Fast Frame can be used for embroidering on to sweat band area of caps, back, sides, peak, bucket caps, collar tips, cuffs of sleeves, dog collars, gym bag centre flaps, etc. Fast Frames should be used in conjunction with Filmoplast adhesive backing.

### Embroidery Software

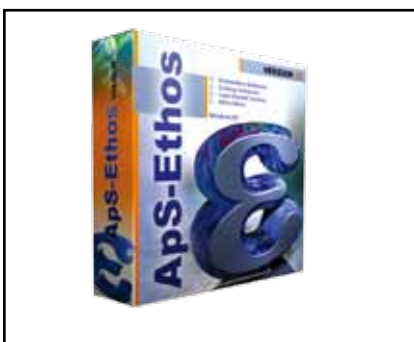

The ApS-Ethos suite of Embroidery and Cutting software has been in development for over 25 years, when CadCam Technology Ltd embarked upon the first of many innovative products designed for the Textiles Industry. During this time our aim has been to create a range of software that is easy to use, yet extremely powerful.

## Other CadCam Technology Products



CadCam have manufactured laser cutting machines for the embroidery industry for many years. Laser technology is used for cutting appliqués and engraving fabric. A more recent development is the reverse appliqué, where a piece of fabric is positioned underneath a garment and then the laser cuts through the top garment, exposing the fabric underneath.

# Merlin Pro



## GS UK Ltd

5 Crocus Street  
Nottingham NG2 3DE

**0115 8448000**

[www.gs-uk.com](http://www.gs-uk.com)  
[sales@gs-uk.com](mailto:sales@gs-uk.com)